

IR Ingersoll-Rand®

AIR TOOLS and COMPRESSORS

Professional Solutions



the
best way
to predict
the future is to

INVENT IT

Air Ratchets & Air Impact Tools

They're the most important tools in your shop. Compact. Convenient. Real time-savers. Air Ratchet Wrenches and Air Impact Tools have become essential elements in every serious toolbox. They combine access and power to make jobs more productive and profitable. **Ingersoll-Rand** gives you the widest selection of impact tools in the industry and our ratchets feature unique qualities that you won't find anywhere else.



The TwinPawl Plus™ head design, utilizes a patented spring and damper system to ensure positive engagement of the pawls in the ratcheting mechanism, to eliminate skipping and lock-up.



The XP logo identifies tools upgraded with enhanced features to deliver Extra Performance.



The twin hammer mechanism delivers simultaneous, balanced blows to the anvil, for maximum power output, efficiency and smoothness.



The TwinHammer Plus mechanism combines new geometry and materials to further enhance durability and efficiency on the industry's leading tools.

the new generation AIR RATCHET WRENCHES

1103 1/4" & 1133 3/8" ULTRA DUTY

High performance composite mini ratchet wrenches



Free Speed: 270 rpm
Maximum Torque: 25 ft.-lbs.
Working Torque: 5 – 25 ft.-lbs.

New concept with ergonomic design and a durable composite housing. These ultra duty mini ratchets were the first of the new generation of ratchets from IR. The tools have a two speed power grip ring for ease and versatility. The TwinPawl Plus head design eliminates skipping and lock-up. Other features include heat treated ratchet head, directional exhaust and textured handle for superior comfort and grip.



1200 3/8" & 1210 1/2" ULTRA DUTY

High performance composite ratchet wrenches



Free Speed: 275 rpm
Maximum Torque: 60 ft.-lbs.
Working Torque: 10 – 50 ft.-lbs.

The latest in the new generation ultra duty ratchets from IR. New concept with ergonomic design and a durable lightweight composite housing. This tool handle offers superior comfort and grip. The new head design features IR exclusive TwinPawl Plus slip resistant friction disc for longer life and high speed durability. Other features include swivel inlet, 4 vane off-set motor, two finder variable throttle and 360° directional exhaust.



170 3/8" & 1770 1/2" STANDARD DUTY Powerful ratchet wrenches

Free Speed: 160 rpm
Maximum Torque: 60 ft.-lbs.
Working Torque: 10 – 55 ft.-lbs.

- High quality at affordable price.
- Fast run down for efficient operation.
- Compact head for confined areas.



103A 1/4" & 1033A 3/8" ULTRA DUTY Stubby ratchet wrenches

Free Speed: 200 rpm
Maximum Torque: 20 ft.-lbs.
Working Torque: 5 – 20 ft.-lbs.

- Stubby ratchets for faster work in confined spaces.
- Two of the smallest air ratchets available, 165mm long.
- Heat treated, hardened steel yoke.



107XP 3/8" & 1077XP 1/2" HEAVY DUTY Durable ratchet wrenches

Free Speed: 160 rpm
Maximum Torque: 50 ft.-lbs.
Working Torque: 10 – 45 ft.-lbs.

- Technologically advanced head design for extra durability.
- Variable speed lever style throttle.
- Ideal reversible tools for body shop work, radiator removal and replacement, engine and exhaust work.
- 360° adjustable exhaust.



109XP 3/8" & 1099XP 1/2" SUPER DUTY Powerful ratchet wrenches

Free Speed: 300 rpm
Maximum Torque: 70 ft.-lbs.
Working Torque: 10 – 60 ft.-lbs.

- Enhanced mechanism makes this the fastest ratchet in its class!
- Provides convenient access to confined spaces.
- 360° adjustable exhaust.
- Push button throttle.



111 3/8" & 1111 1/2" SUPER DUTY The Knuckle Saver™

Free Speed: 300 rpm
Maximum Torque: 50 ft.-lbs.
Working Torque: 10 – 50 ft.-lbs.

- Reaction-less ratchet – A unique impact mechanism eliminates torque reaction, thereby saving your knuckles.
- Two and half times faster than standard ratchets.
- Ideal for the toughest automotive applications.



the ultimate

AIR IMPACT WRENCHES - TITANIUM

• LIGHTWEIGHT • STRENGTH • DURABILITY

2115Ti 3/8"

Light and powerful mini impact wrench



Maximum Torque: 250 ft.-lbs. (280 reverse)

Working Torque: 25 – 230 ft.-lbs.

The lightest, most powerful, 3/8" impact wrench on the market today. At only 142mm long, this tool can be used comfortably in confined spaces. The titanium offers unbeatable strength and durability in the toughest applications and features the proven TwinHammer Plus impact mechanism.



2125QTi 1/2"

Light and powerful mini impact wrenches



Maximum Torque: 250 ft.-lbs. (280 reverse)

Working Torque: 25 – 230 ft.-lbs.

The 1/2" version of the new Model 2115Ti Titanium impact wrench. Superior power in a lightweight package complete with 'Quiet Tool' technology.



2135Ti, 2135Ti-2, 2135QTi & 2135QTi-2 1/2"

A premium technology tool with unbeatable performance



Maximum Torque: 625 ft.-lbs. (700 reverse)

Working Torque: 50 – 600 ft.-lbs.

1000 ft.-lbs of Nut Busting Torque

No other 1/2" impact wrench comes close to the power and performance

of our new TwinHammer 2135 series Titanium impact wrenches. The seven vane motor delivers breakaway torque that will loosen a nut tightened to 1000 ft. lbs.– in mere seconds. Easy to use, one handed forward/reverse push buttons, a professional touch trigger for smooth power delivery and an ergonomically advanced handle for increased comfort and improved grip control. Other features include four position power management control, a through handle exhaust system and 360° swivel inlet.

Available in the following configurations:
Model 2135Ti: with Standard Anvil
Model 2135Ti-2: with 2" Extended Anvil
Model 2135QTi: with 'Quiet Tool' technology
Model 2135QTi-2: with 2" Extended Anvil and 'Quiet Tool' technology



232TGTi 1/2"

The fastest impact wrench



Maximum Torque: 650 ft.-lbs. (625 reverse)

Working Torque: 40 – 400 ft.-lbs.

Legendary ThunderGun performance now available in Titanium for increased durability in a lightweight package. New improved seven vane motor offers increased 10,000 rpm performance to remove the toughest nut. Other features include distinctive racing appearance and adjustable regulator.



2190Ti, 2190Ti-6 & 2190DTi-6 1"

High power and superior ergonomic impact wrenches



Maximum Torque: 1600 ft.-lbs. (1650 reverse)

Working Torque: 150 – 1200 ft.-lbs.

The newest member of the Titanium Team. Designed specifically for tyre changing, the chainsaw handle model provides comfortable control for the operator. The revolutionary handle design allows the operator to grip the tool in a more natural and comfortable position. Minimises bending and squatting with less arm and shoulder back pain. These Titanium models deliver devastating torque in a lightweight package. Weighs 50% less than other 1" impact wrenches. Also available in extended anvil and "D" handle versions. The anvil is made from 25mm high strength steel complete with combination pin hole and "O" ring retention. Other features include TwinHammer mechanism, titanium hammer case, high torque 7 vane motor, convenient 3 position power settings and full power reverse mode, ergonomically advanced handle design and 360° adjustable front handle.

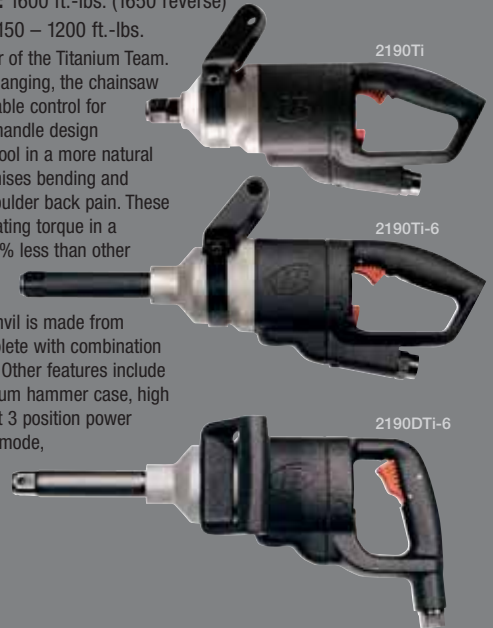

2925Ti Series

Classic IR reliability meets titanium toughness



Ingersoll Rand's line of 2925Ti impacttools have evolved to reflect our new abilities. The new Model 2925 Titanium tools are a blend of our best patented technologies and advanced materials designed to help make your job easier by cutting the toughest bolting jobs down to size. Features include Titanium hammer case, corrosion resistant treatment on internal parts, internal muffler, ergonomic handle, 4 position power regulator, durable textured non-slip grip and solid course thread air inlet.

Pistol Grip

2925P1Ti 3/4"

Maximum Torque: 1450 ft.lbs

Working Torque: 350 – 1100 ft.lbs



2925RBP1Ti 3/4"

Maximum Torque: 1300 ft.lbs (1600 reverse)

Working Torque: 300 – 950 ft.lbs (400 – 1400 reverse)

2925P3Ti 1"

Maximum Torque: 1450 ft.lbs

Working Torque: 350 – 1100 ft.lbs

2925RBP3Ti 1"

Maximum Torque: 1300 ft.lbs (1600 reverse)

Working Torque: 300 – 950 ft.lbs (400 – 1400 reverse)

'D' Handle

2925B2Ti 1"

Maximum Torque: 1600 ft.lbs

Working Torque: 350 – 1400 ft.lbs



2925RB2Ti 1"

Maximum Torque: 1500 ft.lbs (1700 reverse)

Working Torque: 300 – 1300 ft.lbs (400 – 1500 reverse)

3900Ti Series

A new generation of power



Ingersoll Rand's line of 3900Ti impacttools offer the strongest, most durable, longest life mechanism in the world. The new 3900Ti series features include Titanium hammer case, twin hammer mechanism, reverse biased brass end-plates, integrated muffler, integrated reverse lever and high performance 7 vane motor. Each product is laser etched with product information that will last the life of the tool.

3940B2Ti 1"

Maximum Torque: 2500 ft.lbs (2750 reverse)

Working Torque: 500 – 1650 ft.lbs
(500 – 1800 reverse)



3942B2Ti 1"

Maximum Torque: 2750 ft.lbs (3250 reverse)

Working Torque: 1000 – 1800 ft.lbs (1000 – 2100 reverse)

'Q' Models - Quiet Technology

Quiet technology utilises the reflective method of noise reduction. This technology when applied does not clog or degrade the tool performance or restrict air flow or create back pressure. The baffle does not wear out or need to be replaced.



air impact wrenches

216 3/8"

SUPER DUTY Palm grip impact wrench

Max Torque: 175 ft.-lbs.

Working Torque: 15 – 160 ft.-lbs.

- Ideal for work in confined spaces.
- Powerful pin-clutch mechanism.
- Recessed regulator dial.
- Handle exhaust.
- 180° swivel inlet.
- Butterfly style throttle for smooth forward/reverse control.



131S-EA & 131S-EA-2 1/2"

SUPER DUTY Ergonomic impact wrenches

Maximum Torque: 450 ft.-lbs.

Working Torque: 25 – 300 ft.-lbs.

- Pressure feed lubrication.
- Adjustable power regulator for control of power output.
- Ergonomic handle and trigger.
- In-handle exhaust.
- Available with 2" extended anvil (Model: 131S-EA-2).



231C 1/2"

SUPER DUTY The classic popular impact wrench

Max. Torque: 425 ft.-lbs. (600 reverse)

Working Torque: 25 – 300 ft.-lbs.

- TwinHammer Plus mechanism.
- Pressure-feed lubrication system.
- Variable speed trigger for control of power output.
- Adjustable power regulator.
- Front exhaust.



232TGSL 1/2"

SUPER DUTY The fastest impact wrenches

Maximum Torque: 500 ft.-lbs. (625 reverse)

Working Torque: 40 – 400 ft.-lbs.

- Seven vane hi-speed motor.
- Distinctive racing appearance.
- Adjustable power regulator.
- Our fastest 1/2" impact wrench – 10,000 rpm.
- Also available with titanium hammer case to increase durability in a lightweight package (Model: 232GTI).



252 3/4"

STANDARD DUTY The economical 3/4" impact wrench

Maximum Torque: 750 ft.-lbs.

Working Torque: 100 – 500 ft.-lbs.

- High power rating.
- Powerful pin-clutch mechanism.
- Compact size.
- Adjustable 3 position power regulator in forward.
- Full power in reverse.
- In-handle exhaust directs exhaust air away from work area.
- Integral 360° swivel inlet eliminates twisted hoses.
- Oil bath lubrication system.



215 3/8"

SUPER DUTY Powerful and economical impact wrench

Maximum Torque: 160 ft.-lbs.

Working Torque: 15 – 129 ft.-lbs.

- Compact design for faster work in confined spaces.
- Variable tease trigger control.
- Six position power management.
- Powerful pin-clutch mechanism.



225 1/2"

HEAVY DUTY Mini impact wrench

Maximum Torque: 325 ft.-lbs.

Working Torque: 25 – 200 ft.-lbs.

- Mini impact tool for work in confined spaces.
- Variable tease trigger control.
- 6 position power management.
- Powerful pin-clutch mechanism.
- In-handle exhaust.



2130 & 2130-2 1/2"

HEAVY DUTY Composite housed impact wrenches

Maximum Torque: 600 ft.-lbs.

Working Torque: 25 – 300 ft.-lbs. (500 reverse)

- Powerful TwinHammer mechanism.
- New composite housing.
- Superior ergonomics.
- Lightweight package.
- Full stroke tease throttle.
- Easy glide forward/reverse switch.
- Multi-position power management.
- Lightweight reinforced aluminium hammer case.
- Available with 2" extended anvil (Model: 2130-2).



2141 3/4"

ULTRA DUTY A high performance 3/4" impact wrench

Maximum Torque: 1100 ft.-lbs. (1200 reverse)

Working Torque: 200 – 900 ft.-lbs.

- Best-in-class torque.
- Maneuverability for tight, awkward spaces.
- Durable composite housing with steel hammer case.
- TwinHammer Plus mechanism provides maximum durability.
- Four position power regulator and forward/reverse control.
- Contoured professional touch trigger and ergonomically designed handle.
- In-handle exhaust and 360° swivel inlet.



258 & 258A-3 3/4"

HEAVY DUTY The high power-to-weight ratio 3/4" impact wrench

Maximum Torque: 1000 ft.-lbs.

Working Torque: 200 – 800 ft.-lbs.

- High quality at an affordable price.
- Powerful pin-clutch mechanism.
- Adjustable power in forward mode.
- Full power in reverse.
- Silenced, in-handle exhaust.
- Integral 360° swivel inlet eliminates twisted hoses.
- Available with 3" extended anvil (Model: 258A-3).



air impact wrenches

261, 261-3 & 261-6 3/4"

SUPER DUTY High power output 3/4" impact wrench

Maximum Torque: 1100 ft.-lbs.

Working Torque: 200 – 900 ft.-lbs.

- Jumbo hammer mechanism.
- Pressure feed lube system for trouble free performance.
- Adjustable power regulator system.
- In-handle exhaust.
- Available with 3" and 6" extended anvils (Model: 261-3 and 261-6).



271 1"

SUPER DUTY High power to weight ratio output

Maximum Torque: 1100 ft.-lbs.

Working Torque: 100 – 750 ft.-lbs.

- High power-to-weight ratio.
- Jumbo hammer impact mechanism.
- Pressure feed lubrication system.
- Supplied with side handle for improved operator control.



295 1"

HEAVY DUTY Power and convenience

Maximum Torque: 1450 ft.-lbs.

Working Torque: 100 – 1000 ft.-lbs.

- Compact and lightweight.
- Durable rocking dog mechanism.
- In-handle exhaust.
- Top-mounted handle.
- 3 position power regulator.

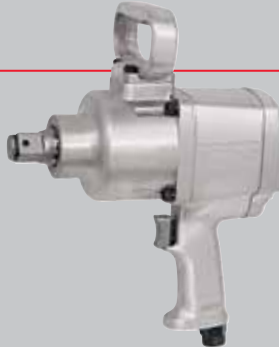

2171XP 1"

ULTRA DUTY The smallest tool in its class

Maximum Torque: 1250 ft.-lbs.

Working Torque: 300 – 1000 ft.-lbs.

- 6 vane high output motor.
- TwinHammer mechanism.
- Ergonomic handle and housing design.
- High power-to-weight ratio.
- Full power reverse.
- 3 position power regulator.
- 360° swivel inlet.
- In-handle exhaust.



2940P2 1"

SUPER DUTY The toughest 1" impact wrench

Maximum Torque: 2000 ft.-lbs.

Working Torque: 1600 ft.-lbs.

- Cast iron hammer case.
- Integrated muffler.
- Built in lubrication.
- Integral power regulator.
- Spade style dead handle.



2161XP & 2161XP-6 3/4"

ULTRA DUTY Impact wrenches for high production work

Maximum Torque: 1250 ft.-lbs.

Working Torque: 300 – 1000 ft.-lbs.

- 6 vane high output motor.
- TwinHammer mechanism.
- Pressure feed lube system.
- Full power reverse.
- 3 position power regulator.
- In-line handle exhaust.
- 360° swivel outlet.
- Available with 6" extended anvil (Model: 2161XP-6).



285A & 285A-6 1"

HEAVY DUTY Exceptional power, durability and operator convenience

Maximum Torque: 1450 ft.-lbs.

Working Torque: 100 – 1000 ft.-lbs.

- Superior balance.
- Durable rocking dog mechanism.
- 'Angled down' exhaust.
- Adjustable side handle.
- High efficiency 6 vane motor.
- 3 position power regulator.
- Available with 6" extended anvil (Model: 285A-6).
- Available with spline anvil (Model: 285A-S6).

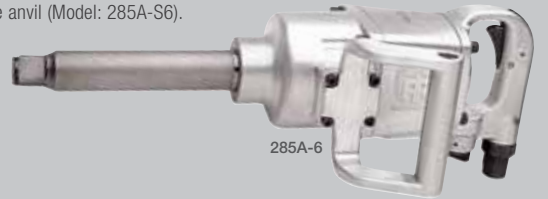

2150 1"

ULTRA DUTY Lightweight and powerful

Maximum Torque: 1100 ft.-lbs. (1200 reverse)

Working Torque: 200 – 900 ft.-lbs.

- Spark resistant construction.
- Compact and lightweight.
- In-handle exhaust.
- Composite body and handle.
- 4 position power regulator.



293 1"

SUPER DUTY The powerful 1" impact wrench

Maximum Torque: 2000 ft.-lbs.

Working Torque: 1000 – 1600 ft.-lbs.

- Built-in pressure feed lube system.
- Long-lasting tool.
- Compact and lightweight.
- In-handle exhaust.
- Available with spline anvil (Model: 293-S).



2950B7 1 1/2"

SUPER DUTY Powerful industrial grade 1 1/2" impact wrench

Maximum Torque: 3000 ft.-lbs.

Working Torque: 1600 – 2500 ft.-lbs.

- Twinhammer mechanism.
- Direct drive for fast run down.
- Durable epoxy coated motor housing.
- Pressure feed impact mechanism lubrication.
- Two piece motor housing.



the ultimate AIR DIE GRINDERS

3102

SUPER DUTY

Performance and versatility in a lightweight package

Free Speed: 20,000 rpm

With all ball bearing constructions, you get longer lasting life and advanced durability, along with a composite grip for superior ergonomics and comfort. This powerful die grinder can be used in various applications including porting, weld braking, de-burring, polishing and grinding. The powerful 0.33 hp motor is housed in a lightweight, ergonomic yet durable design.

- Safety release throttle.
- Multi-positional head.
- Standard 1/4" (6mm) collet for all types of accessories.



3108

SUPER DUTY

Performance and versatility in a lightweight package

Free Speed: 25,000 rpm

Same features and specifications as Model 3102, but with a versatile straight die grinder head configuration.



301A

STANDARD DUTY Mini Air Angle Die Grinder

Free Speed: 20,000 rpm

- Powerful 0.25 hp motor.
- Ball bearing construction for durability.
- Precision machined gearing delivers maximum power transfer.
- Also available in kit form – refer below.
- Standard 1/4" (6mm) collet for all types of accessories.



307A

STANDARD DUTY Mini Air Die Grinder

Free Speed: 27,000 rpm

- Powerful 0.25 hp motor.
- Superior maneuverability.
- Safety lever prevents accidental starts.
- Front exhaust helps keep work surface clean.
- Also available in kit form – refer below.
- Standard 1/4" (6mm) collet for all types of accessories.

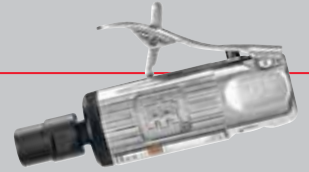

302A

HEAVY DUTY Air Angle Die Grinder

Free Speed: 18,000 rpm

- Powerful 0.33 hp motor.
- Durable and long lasting.
- All ball bearing construction.
- Precise machined steel gears.
- Self-locking throttle lever.
- Standard 1/4" (6mm) collet for all types of accessories.



308A

HEAVY DUTY Air Die Grinder

Free Speed: 25,000 rpm

- Powerful 0.33 hp motor.
- Ball bearing construction for longer life tool.
- Self-locking throttle lever.
- Includes two collet wrenches.
- Standard 1/4" (6mm) collet for all types of accessories.



Air Die Grinder Kits

Die grinder kits are available to suit a variety of grinding and polishing applications.

301-K

Die Grinder Kit

Model 301A is also available in a strong, blow-molded plastic case complete with 10 mounted grinding tips.



307-K

Die Grinder Kit

Model 307A is also available in a strong, blow-molded plastic case complete with 10 mounted grinding tips.



301-2MK Surface Conditioning Kit

Model 301A is also available in a strong, blow-molded plastic case along with four coarse and four medium grit 2" 3M Roloc™ surface conditioning pads and a disc holder.

This kit includes the following accessories:

- 8 x 2" Roloc™ surface conditioning discs.
- 1 x 2" pad holder.



301-3MK Surface Conditioning Kit

Model 301A is also available in a strong, blow-molded plastic case along with four coarse and four medium grit 3" 3M Roloc™ surface conditioning pads and a disc holder.

This kit includes the following accessories:

- 8 x 3" Roloc™ surface conditioning discs.
- 1 x 3" pad holder.



301-32MK Surface Conditioning Kit

Model 301A is also available in a strong, blow-molded plastic case along with two coarse and two medium grit 3" 3M Roloc™ surface conditioning pads, two coarse and two medium grit 2" 3M Roloc™ surface conditioning pads and a disc holder. This kit includes the following accessories:

- 4 x 2" Roloc™ surface conditioning discs.
- 4 x 3" Roloc™ surface conditioning discs.
- 1 x 2" pad holder.
- 1 x 3" pad holder.



the ultimate AIR GRINDERS

344 4" (100mm)

SUPER DUTY

High performance air angle grinder

Free Speed: 12,000 rpm

The new Model 344 is the perfect choice for high performance finishing. This 4" Air Angle Grinder combines a unique motor controller that virtually eliminates over-speeding with a powerful 0.8 hp motor to provide plenty of power for rust and material removal.

- Rear exhaust with piped-away option.
- Composite grip for improved comfort.
- Locking lever with tease throttle.
- Lightweight design.
- Spindle $\frac{3}{8}$ ".



3445 4 1/2" (115mm)

SUPER DUTY

High performance air angle grinder

Free Speed: 12,000 rpm

Same features and specifications as Model 344, but now available with $\frac{5}{8}$ " spindle and 4 1/2" disc capacity.



LA421-EU 4" (100mm)

STANDARD DUTY Air Angle Grinder

Free Speed: 12,000 rpm

All purpose air angle grinder suitable for metal dressing, rust removal, weld preparation and automotive bodywork fabrication.

- Locking lever with tease throttle.
- Includes arbor wrench, flange nut and 4" wheel.



LA422-EU 5" (125mm)

STANDARD DUTY Air Angle Grinder

Free Speed: 12,000 rpm

Same features and specifications as Model LA421-EU however with 5" wheel.

- Includes arbor wrench, flange nut and 5" wheel.



tyre buffers

327

HEAVY DUTY Air High-Speed Tyre Buffer

Free Speed: 22,000 rpm

Model 327 will make quick work of patchwork and roughing up low areas for recapping, tyre scuffing and cleaning tyre mouldings.

- Lever throttle for easy operation.
- Rear exhaust keeps air away from you and your work.
- 10mm keyed chuck.
- Powerful 0.5 hp motor.



327LS

HEAVY DUTY Air Low-Speed Tyre Buffer

Free Speed: 3,000 rpm

Features convenient quick change chuck, built-in regulator and lever-style throttle make patchwork, roughing areas for recapping and cleaning tyre mouldings a breeze.

- Lever-style Tease Trigger with lock-off for easy operation and protection against accidental start-up.
- Quick Change chuck for easy buffing wheel change.
- Piped-away exhaust (included) blows air away from work area and operator.
- Convenient Hanger – keeps tool within easy reach.
- Powerful 0.5 hp motor.



air nibbler / air cut off tool / air saws / air shear

325

HEAVY DUTY Air Nibbler

Speed: 3,200 spm*

- Cuts out quarter panels up to 18 gauge (1.22mm) without distorting the edges of the material.
- Starts cuts in the centre of a panel.
- Holds a tight 1/4" radius with great accuracy.
- Easy to operate and control.
- Balanced, lightweight tool.

*SPM = Strokes per minute



326

HEAVY DUTY Air Cut-Off Tool

Free Speed: 18,000 rpm

- Spindle $\frac{3}{8}$ ", Cutting disc 2 7/8".
- Fast and quiet operation.
- Contoured lever throttle with positive self-locking action.
- Built-in speed regulator.
- 360° rotatable chrome-plated spark guard.



429

HEAVY DUTY Reciprocating Saw

Speed: 10,000 spm*

- Reduced vibration tool.
- For cutting intricate shapes and light radius curves.
- Includes 3 fine and 3 course high-speed steel cutting blades and two hex wrenches.
- Cut on flat and curved surfaces.
- Durable, long-life tool.

*SPM = Strokes per minute



4429

SUPER HEAVY DUTY Reciprocating Saw

Speed: 5,750 spm*

- Contoured design and rubber grip for increased comfort.
- Designed for all types of body, exhaust and muffler work, cutting of aluminium, plastics, fibreglass and sheet metal.
- Adjustable guard.
- Integral power regulator.
- Low vibration.

*SPM = Strokes per minute

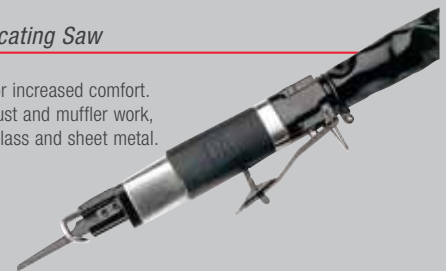

7802SA

HEAVY DUTY Air Shear

Speed: 4,200 spm*

- Clean cuts in cold rolled steel up to 20 gauge (0.91mm) without chips
- Ideal for body shops, sheet metal shops, air conditioning fabricators, plastic fabricators, heating contractors and machine shops.
- Cuts squares, angles and circles.
- Long-life tool with heavy-duty cutting blades.
- Shears most types of plastics and all types of aluminum, tin and steel.

*SPM = Strokes per minute



the ultimate AIR SANDERS



Eight 'vacuum ready' models covering all types of professional sanding applications

New high performance 4151 series Random Orbital Sanders

The 4151 professional range of sanders have been designed for body shop applications requiring high performance finishing. For a quality, swirl free finish on all types of surface preparation and re-finishing, you can depend on these models. And with oil free operation you need not worry about surface contamination. These Random Orbital Sanders are light weight, yet packed with the power of a 0.2 hp motor. Designed for comfort and durability, the 4151 series is the ultimate in low vibration, high performance sanding.

Model	Free Speed rpm	Orbit	Pad Size
Stick-On			
4151	12,000	3/16" / 5mm	6" / 152mm
4151-2 (Extended Handle)	12,000	3/16" / 5mm	6" / 152mm
4151-5 (5" / 127mm Pad)	12,000	3/16" / 5mm	5" / 127mm
Hook & Loop (Velcro)			
4151-HL	12,000	3/16" / 5mm	6" / 152mm
4151-HL-2 (Extended Handle)	12,000	3/16" / 5mm	6" / 152mm



4151
4151-5
4151-HL



4151-2
4151-HL-2

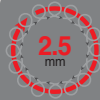
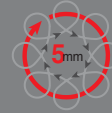

Model	Free Speed rpm	Orbit	Pad Size
Stick-On			
4152	12,000	3/32" / 2.5mm	6" / 152mm
Hook & Loop (Velcro)			
4152-HL	12,000	3/32" / 2.5mm	6" / 152mm

Finishing sanders for bodywork professionals

The 4152 professional range of finishing sanders offer the same high quality features as the 4151 series however with a 2.5mm orbit which is recommended for highest quality finishing applications.

The 'Spot Repair' sander for a smooth finish

The new addition to the 4151 and 4152 family, Model 4152-HL-SR is an indispensable tool, perfect for small alterations and spot repairs. This sander combines all the characteristics of the whole series: Superior ergonomics, lightweight, lube free, optimum speed, a 0.2 hp motor and is vacuum ready. Model 4152-HL-SR has a sanding pad of just 75mm and an orbit of 2.5mm for accurate sanding and a quality finish.

Model	Free Speed rpm	Orbit	Pad Size
Hook & Loop (Velcro)			
4152-HL-SR	12,000	3/32" / 2.5mm	3" / 75mm



4151JV

Jet-Vac Dust Extractor Conversion Kit

Combine any 4151 or 4152 sander with the powerful jet-vac dust extraction system. Influenced by jet engine technology, the jet-vac tool sucks up more air than it takes to actually run the tool!

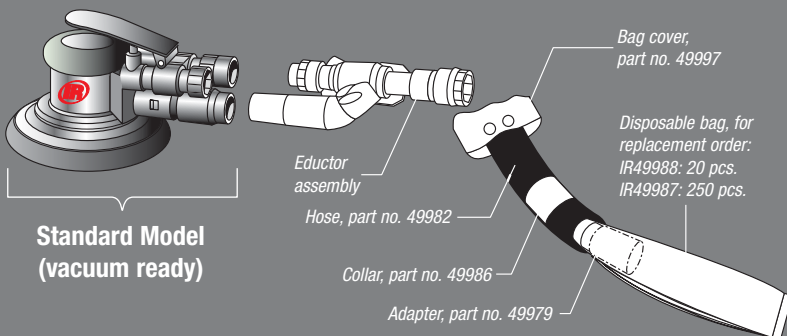

air sanders

311A 6" (152mm) Pad

HEAVY DUTY Air Dual Action Quiet Sander

Free Speed: 10,000 rpm

A built-in silencer muffles noise as you work with this economical dual action sander. It's a quality sander used for feather edging, metal preparation and finish work on body filler. And its dual action pad motion produces swirl-free finishes.

- 0.2 hp motor.
- Vibration-free.
- Dependable performance.
- Balanced ball bearing construction.
- Adjustable built-in regulator for positive speed control.



312A 3 2/3" x 6 3/4" (92 x 171mm) Pad

HEAVY DUTY Air ORBITAL Sander

Free Speed: 8,000 rpm

Model 312A Air Orbital Sander makes fast work of smoothing fibreglass, wood and body filler and takes care of any sanding job on paint, metal and fibreglass. The compact, contoured palm-grip allows you to run Model 312A with one hand!

- 0.3 hp motor.
- Low vibration plus longer life.
- Balanced ball bearing construction.
- Automatic release throttle lever with positive stop action.
- Built-in regulator for positive speed control.
- Positive locking clamps.

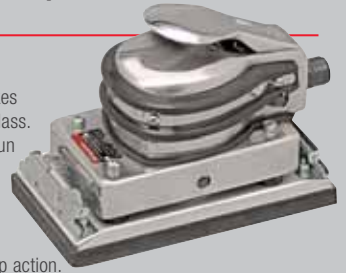

313A 7" (178mm) Pad

HEAVY DUTY Air Angle Sander

Free Speed: 5,000 rpm

With Model 313A you can work faster on light and heavy sanding jobs, including roughing body filler, removing rust and smoothing welds.

- Heavy duty motor handles tough jobs.
- Ball bearing construction for long-life.
- Lightweight, only 1.9Kgs.



315 2 3/4" x 17 1/2" (70 x 455mm) Pad

HEAVY DUTY Air Twin Piston Straight Line Sander

Speed: 3,000 spm*

The twin piston design keeps extra power in reserve to prevent stalling and tackle sanding jobs like smoothing down body filler or shaping and levelling large flat surfaces.

- Reciprocating type stroke length.
- Quick action paper clamps.
- Smooth, reliable power.

*SPM = Strokes per minute



317A 5" (125mm) Pad

HEAVY DUTY Air High Speed Sander

Free Speed: 18,000 rpm

For small jobs and hard-to-reach places, Model 317A is an economical high-speed sander for light sanding, feather edging and rust removal.

- Easy to handle, compact and lightweight.
- Built-in power regulator.
- Comes with three backing pads: 1 each 3", 1 each 4" and 1 each 5" (stackable).



319A 7" (178mm) Pad

HEAVY DUTY Air Vertical Sander

Free Speed: 5,000 rpm

A high quality sander made to handle demanding jobs like rust removal and sanding metal and body filler, Model 319A comes complete with one 7" backing pad.

- Longer gear life plus better gearing for better power.
- Planetary gear reduction feature.
- Lever throttle for speed control.
- Handle exhaust directs air away from work area.



328B 8" (203mm) Pad

HEAVY DUTY Air Geared ORBITAL Sander

Free Speed: 8,250 rpm

The smooth strength and power of this air geared orbital sander lets you remove heavy material and body filler on large, flat surfaces leaving a clean, swirl-free finish.

- 0.25 hp motor.
- 5/32" (4mm) orbit.
- Dual action pad motion.
- A long-life, vibration-free performance.
- Balanced ball bearing construction.



air polishers

314A 7" (178mm) Pad

HEAVY DUTY Air Angle Polisher/Buffer

Free Speed: 2,500 rpm

A versatile tool with a high free speed range of 1,500 – 2,500 rpm for buffing and polishing a wide range of surfaces – paint, metal and plastic – to a high-gloss, professional finish. With its heavy duty motor, this polisher can handle the toughest jobs.

- Long-life, ball bearing construction.
- Dead handle and spindle for easy handling.
- Built-in regulator.



318A 7" (178mm) Pad

HEAVY DUTY Air Vertical Polisher/Buffer

Free Speed: 2,800 rpm

Buff and polish all painted surfaces easily. This compact, lightweight vertical polisher/buffer gives you the results you want, even on the tough jobs. The variable speed control lever throttle helps eliminate paint burning. Comes complete with a 7" backing pad.

- Long tool life from the planetary gear reduction feature.
- Plenty of power from the 1 hp motor.
- Handle exhaust directs air away from work area.



the ultimate AIR DRILLS

7802A & 7802RA

HEAVY DUTY

Keyed Chuck 3/8" (10mm)

Industrial, compact air drills

Free Speed: 2,000 rpm

With its industrial grade 3/8" chuck, these professional choice drills include high quality features for general drilling and hole sawing jobs. The planetary gear reduction balances the load on bearings and gears for increased tool life.

- 0.5 hp motor.
- Variable speed throttle for starting holes easily.
- Lightweight and compact for smooth and easy handling.
- More power and long life tool.
- Model 7802RA has the added feature of a reversible motor with a quick function reverse lever.



7802AKC & 7802RAKC

HEAVY DUTY

Keyless Chuck 3/8" (10mm)

Industrial, compact air drills

Free Speed: 2,000 rpm

Same features and specifications as the Models 7802A and 7802RA, but with keyless chuck for fast and easy bit changes.



7803A & 7803RA

HEAVY DUTY

Keyed Chuck 1/2" (13mm)

The professionals choice

Free Speed: 500 rpm

Here's the professional choice for power, these high quality air drills are designed for drilling, hole sawing, cylinder honing and any other job that calls for a 1/2" chuck. Features include heavy duty ball and needle bearing construction and double reduction planetary gearing that balances the load.

- 0.5 hp motor.
- Variable speed throttle for starting holes easily.
- Lightweight and compact for smooth and easy handling.
- More power and long tool life.
- Auxiliary side handle.
- Model 7803RA has the added feature of a reversible motor with a quick function reverse lever.

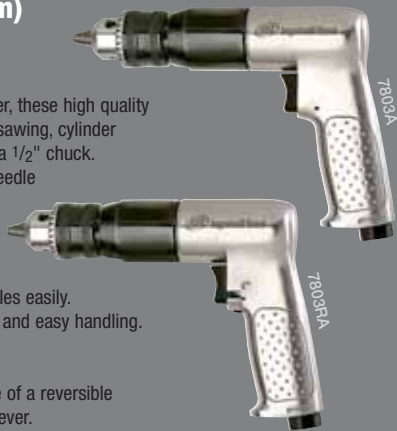

7803AKC & 7803RAKC

HEAVY DUTY

Keyless Chuck 1/2" (13mm)

The professionals choice

Free Speed: 500 rpm

Same features and specifications as the Models 7803A and 7803RA, but with keyless chuck for fast and easy bit changes.



7807R

Keyed Chuck 3/8" (10mm)

STANDARD DUTY Air Angle Reversible Drill

Free Speed: 1,800 rpm

Rated Power: 0.33 hp

One in a new family of economical, standard duty tools, Model 7807R is an excellent choice for service work requiring a compact, low profile angle head. It's a durable, reliable tool for drilling in all types of materials, including sheet metal, wood and composites.

- Durable Jacobs multi-craft chuck.
- Reversible, with convenient control.
- Comfortable lever throttle.
- Grease plug for easy preventative maintenance.
- Precision machine gearing ensures maximum power transfer and durability.

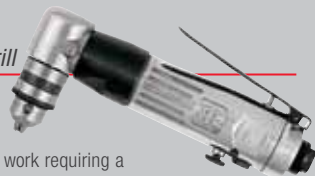

7804R

Keyed Chuck 3/8" (10mm)

SUPER DUTY Air Angle Reversible Drill

Free Speed: 1,200 rpm

Rated Power: 0.5 hp

This premium quality drill provides the convenience of an angle head for working in confined areas. Variable speed lever throttle adds precision for all applications.

- Rear exhaust keeps exhaust air away from the work area.
- Forward/reverse control locks in both positions.
- Plenty of power and torque.

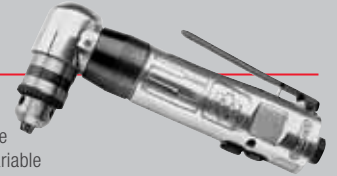

371

STANDARD DUTY Pistol-Grip Reversible Screwdriver

Free Speed: 1,800 rpm

Max. Working Torque: 13 Nm

Model 371 is an excellent choice for soft-draw applications. This tool is well-suited for service work on HVAC systems, instrument panels and trim components. It delivers reliable performance for driving of sheet metal, self tapping and wood screws.

- Positive action clutch, for full torque throughout rundown.
- Convenient one-handed operation, with reverse control at trigger.
- Variable speed throttle for easy starts.
- Through-handle exhaust.
- Compact, lightweight and maneuverable.



the ultimate AIR HAMMERS

132

Air hammer

Blows per minute: 1,725 bpm
Bore Diameter: 14mm
Stroke Length: 102mm

Professionals who want the best choose this tool for front end work, heavy exhaust work, rivetting, king pin removal, bushing driving and bolt shearing.

- Extra-sensitive tease throttle controls starting strokes.
- Longer stroke piston.
- Replacement Retainers: Beehive Retainer (as shown) P/N AVC1-83, Spring Retainer P/N AVC10-183A.



SUPER DUTY

115

STANDARD DUTY Air Hammer

Blows per minute: 5,000 bpm
Bore Diameter: 19mm
Stroke Length: 41mm

This powerful, yet economical high-speed air hammer, is designed for light exhaust system work and general cutting, chipping and scraping.

- Alloyed steel barrel and heat-treated piston for longer life.
- Built-in power regulator and trigger control.
- Replacement Retainer: Spring Retainer P/N 115-183.



116

STANDARD DUTY Air Hammer

Blows per minute: 3,500 bpm
Bore Diameter: 18mm
Stroke Length: 67mm

The economical air hammer for fast cutting action, especially for medium exhaust system, panel cutting and general repair work.

- Handles a range of cutting applications.
- Longer life alloyed steel barrel and heat-treated piston.
- Replacement Retainer: Spring Retainer P/N 115-183.



117

STANDARD DUTY Air Hammer

Blows per minute: 2,000 bpm
Bore Diameter: 18mm
Stroke Length: 89mm

An economical air hammer designed for exhaust work, bolt cutting and front-end work. The trigger control and built-in power regulator give you full control of the speed and power.

- Longer stroke piston.
- Alloyed steel barrel and heat-treated piston for longer life.
- Replacement Retainer: Spring Retainer P/N 115-183.



121

SUPER DUTY Air Hammer

Blows per minute: 3000 bpm
Bore Diameter: 19mm
Stroke Length: 58mm

Make fast work of body panel crimping and cutting, bushing, driving, shearing and general front end work with this super duty air hammer.

- Professional touch trigger for total control.
- Long-life tool with a tough one piece alloy barrel.
- Easy to maintain, with an "easy out" throttle valve assembly.
- Replacement Retainers: Spring Retainer (as shown) P/N AVC10-183A, Beehive Retainer P/N AVC1-83.



Air Hammer Kits

Air hammer kits are available to suit a variety of cutting, edging and punching applications

116K Air Hammer Kits

Model 116 air hammer is also available in a strong blow-molded plastic case with matching five-piece chisel kit. (Chisel Kit can be bought separately.)

117K Air Hammer Kits

Model 117 air hammer is also available in a strong blow-molded plastic case with matching five-piece chisel kit. (Chisel Kit can be bought separately.)

121K6 Air Hammer Kit

Model 121 air hammer is also available in a strong blow-molded plastic case with matching six-piece chisel kit as shown. (Chisel Kit can be bought separately.)



air needle scalers / air chipper tools

125

STANDARD DUTY Needle Scaler (or Chipper)

Blows per minute: 4600 bpm
Bore Diameter: 25mm
Stroke Length: 28.6mm

For surface preparation work involving the cleaning or removal of paint, rust, dirt or weld slag, Model 125 is a durable, dependable, economical solution.

- Needle Qty: 19 needles
- Needle Size: 3.2mm
- Air consumption: 15 cfm

Note: Optional chipper chisels available as below:

Type	Width / Length 7"	Part Number
Blank		PF2200-391
Chisel	3/4" (19mm)	PF2200-392
Wide Chisel	1 3/8" (35mm)	PF2200-393
Angle Chisel	1 3/8" (35mm)	PF2200-394
Scraper	2" (50mm)	PF2200-390
Scraper	3" (75mm)	PF2200-390-3
Diamond Point	1/4" (6mm)	PF2200-3230
Round Nose	1/4" (6mm)	PF2200-3231
Cape Nose	1/4" (6mm)	PF2200-3232



170PG

HEAVY DUTY Needle Scaler (or Chipper)

Blows per minute: 3000 bpm
Bore Diameter: 24mm
Stroke Length: 36mm

This heavy duty pistol grip needle scaler has a constant duty rating and is ideally suited for multiple applications on any surface.

- Needle Qty: 19 needles
- Needle Size: 3.2mm
- Air consumption: 5.5 cfm

Note: Optional chipper chisels available.



170PG shown with optional chisel fitted

172LNA1 & 182LNA1

HEAVY DUTY Needle Scalers (or Chippers)

Blows per minute: 5500 bpm – Model 172LNA1
Blows per minute: 4000 bpm – Model 182LNA1
Bore Diameter: 24mm for both Models
Stroke Length: 14mm – Model 172LNA1
Stroke Length: 24mm – Model 182LNA1

For applications requiring specialised, heavy duty finishing tools. Use for a variety of applications including marine repairs and maintenance, cleaning sand castings, removing unwanted surface deposits, peening and weld splatter and slag removal.

- Needle Qty: 19 needles
- Needle Size: 3mm
- Air consumption: 5.5 cfm

Note: Chipper only models: 172L and 182L available with optional chipper chisels.



182K1

HEAVY DUTY Combined Needle Scaler and Chipper Kit

Dual purpose kit also available which includes needle scaler attachment and straight, angle and flat chisels.



the cast iron guarantee AIR COMPRESSORS

IR Compressors – comparable weight and price but high on features.

A proven, trusted name and world leader in compressed air technology. The range consists of electric and petrol configurations that feature a cast iron pump. Cast iron simply out performs and out lasts its aluminium equivalent. Other features also include: Built to industrial strength for greater reliability, highly efficient slow revving and cool running IR designed pump and rated at 125 psi (862 kpa) pressure for greater productivity.

Electric Models:

Model No.	hp	kw	rpm	Tank Ltrs	Piston Air Disp. Ltrs/Min	CFM	Free Air Del. Ltrs/Min	CFM	Wgt kgs
EL12	2.2	1.65	803	50	314	11.1	217	7.7	71
EL15	3	2.2	942	50	368	13.0	260	9.2	72
EL17	3	2.2	1039	50	406	14.3	280	9.9	73

Petrol Model:

Model No.	hp	kw	rpm	Tank Ltrs	Piston Air Disp. Ltrs/Min	CFM	Free Air Del. Ltrs/Min	CFM	Wgt kgs
EL18P	5.5	4.1	1071	50	419	14.8	296	10.5	75

Note: Petrol model features fully automatic engine idle control.

Note: Displacement and actual delivery based on CAAA protocol 2000.



EL12
EL15
EL17



EL18P

accessories & replacement PARTS

An extensive range of accessories and genuine replacement parts are available from your local distributor to compliment your IR tools. Visit our website at www.irtools.com.au for further information.



DISTRIBUTOR:

IR Ingersoll Rand®

Ingersoll Rand (Australia) Ltd.
Landmark Corporate Centre
Level 2, 454 Nepean Highway
Frankston, Vic 3199 Australia

Phone +61 (0)3 8781 1695
Mobile +61 (0)408 289 366
Fax +61 (0)3 8781 1607
E-mail john_winnett@ap.irco.com

Note: IR reserves the right to discontinue or change the specifications or the design of any product referred to herein.

For additional specific information on Ingersoll Rand products, latest news & detailed product specifications, visit our websites:



www.irtools.com.au



www.irtools.co.nz