



The PressureWave™ Series

PressureWave™ tanks are ideally suited for a wide range of applications, including, booster systems, thermal expansion, irrigation systems, and hydraulic hammer arresting.

The PressureWave™ Series is constructed of a virgin polypropylene liner combined with a FDA approved high grade butyl diaphragm. This is held against the wall of the tank with a steel clench ring. The brass air valve, sealed by a threaded o-ring valve cap prevents air leaks. Water enters the tank through a patented water Stainless Steel water connection. The diaphragm and liner are both reinforced in specific wear areas for longer life. All internal parts including the air valve are rounded to prevent piercing of the diaphragm in extreme conditions. The water connection uniquely provides a dual water/air seal ensuring a complete leak free and maintenance free Pressure Vessel.

On the exterior the almond colored two-part polyurethane paint finish over an epoxy undercoating provides hundreds of hours of UV and salt spray protection.

PressureWave™ tanks are quality tested at several stages on the production line to insure the structural integrity of every tank.

PressureWave™ tanks represent the best value for the investment and are the best quality pressure vessels available today.



Features

- Single diaphragm design
- NSF Standard 61, CE/PED, WRAS approved
- Patented water connection
- Virgin polypropylene liner
- Two part polyurethane, Epoxy primed paint finish
- Leak free o-ring sealed air valve cap
- Comprehensive testing
- No maintenance

Model #'s		Dimensions						Connection	Volume		Shipping (box)		Shipping (box)	
		A		B		C			liter	gal	cu. M	cu. ft	kilos	lbs
BSP	NPT	cm	inches	cm	inches	cm	inches							
PWSA3	PWSA3	11.4	4.6	8.5	3.4			1/2" SS	0.3	0.079	n/a	n/a	0.34	0.75
PWSA5	PWSA5	18.2	7.3	11.6	4.6			1/2" Nylon	0.5	0.132	n/a	n/a	0.65	1.43
PWSA10	PWSA10	14.2	5.7	11.6	4.6			1/2" Nylon	1	0.264	n/a	n/a	0.79	1.74
PWB2	PWN2	18.3	7.3	12.7	5.1			1" BSP/3/4" NPT SS Inline	2	0.5	0.004	0.13	1.0	2.2
PWB8	PWN8	31.7	12.7	20.3	8.1			1" BSP/3/4" NPT SS Inline	8	2.1	0.016	0.55	2.6	5.7
PWB12	PWN12	36.6	14.6	24.4	9.8			1" BSP/3/4" NPT SS Inline	12	3.2	0.023	0.82	3.2	7.0
PWB18	PWN18	36.8	14.7	27.9	11.2			1" BSP/3/4" NPT SS Inline	18	4.8	0.031	1.10	4.3	9.5
PWB24	PWN24	44.4	17.8	29.2	11.7			1" BSP/3/4" NPT SS Inline	24	6	0.042	1.50	5.6	12.3
PWB33	PWN33	60	24	29.2	11.7			1" BSP/3/4" NPT SS Inline	33	8.7	0.049	1.74	7.1	15.6
PWB40	PWN40	41.9	16.8	38.7	15.5			1" BSP/3/4" NPT SS Inline	40	10.6	0.071	2.50	9.0	19.8
Horizontal Models														
PWB20H	PWN20H	43.9	17.6	28.9	11.6	15.1	6.0	1" BSP/1" NPT SS Inline	20	5.3	0.042	1.50	61	13.4
PWB24H	PWN24H	44.4	17.8	31.7	12.7	16.1	6.4	1" BSP/1" NPT SS Inline	24	6	0.057	2.00	5.6	12.3
PWB60H	PWN60H	52.8	21.1	41.4	16.6	21.3	8.5	1" BSP/1" NPT SS Inline	60	14	0.102	3.60	12.8	28.2
PWB80H	PWN80H	72.4	29	41.4	16.6	21.3	8.5	1" BSP/1" NPT SS Inline	80	20	0.133	4.70	17.5	38.5
Vertical Models w/ base														
PWB60V	PWN60V	62.6	25.0	38.8	15.5	10.4	4.2	1" BSP/1" NPT SS Elbow	60	14	0.093	3.30	12.3	27.1
PWB80V	PWN80V	79	31.6	38.8	15.5	10.4	4.2	1" BSP/1" NPT SS Elbow	80	20	0.127	4.50	16.7	36.7

All connections are stainless steel unless stated otherwise. Tank precharge: 28psi/1.9 bar
 Maximum Working Pressure: 146 psi/10bar (Most Pressure Wave models are available in 16Bar)
 Maximum Working Temperature: 200° F/ 90° C

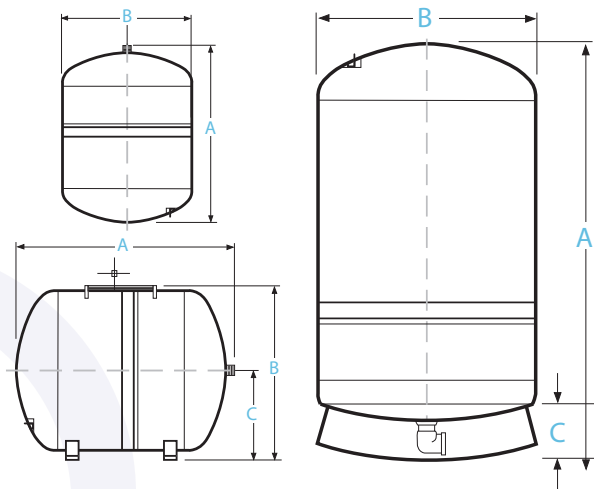
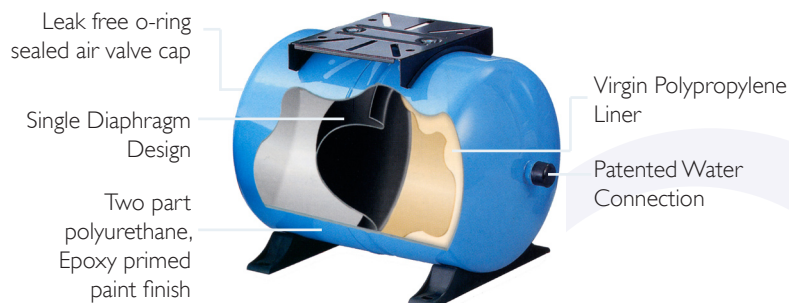

Taiwan Facility

241 Sec. I
 Shen Lin Road
 Daya, Taichung County
 Taiwan
 Tel: +886 4 2560 9763
 Fax: +1 781 658 2511

US Facility

P.O. Box #782
 300 Pond Street
 Randolph, MA 02368
 U.S.A.
 Tel: +1 781 607 2607
 Fax: +1 781 658 2511

Global Water Solutions

P.O. Box #415
 Templar House
 Don Road
 ST. Helier Jersey
 The Channel Islands